



Shandong Shengfei Machinery Co., Ltd.

Tel: +86 150 6628 6136 Fax: +86 (0) 532-84688513

Website: www.shengfeimachinery.com

Email: sales@shengfeimachinery.com

DOUBLE OFFSET HIGH PERFORMANCE BUTTERFLY VALVES



Shandong Shengfei Machinery Co., Ltd. is a professional manufacturer of soft seat, metal seat and fire-safe high performance butterfly valves, our unique seat design is equal to Flowseal and Bray. Under an ISO 9001 Quality Assurance Program, it assures each valve we produce meets or exceeds your application requirements.

SHENGFEI high performance butterfly valves are available in sizes from 2" - 60" in ANSI/ASME, DIN standards etc. and are available with a diverse range of manual and actuated options.

Our high performance butterfly valves are widely used in many industries including heating, ventilating and air conditioning, power generation, hydrocarbon processing, water and waste water treatment, and marine and commercial shipbuilding. Our products are also installed in applications as diverse as food and beverage processing, snow-making and pulp and paper production.

Configurations are available for harsh conditions as well as applications requiring nominal pressure and temperature ratings.

High Performance Applications

Construction

Chemical / Petro-Chemical

Liquified Gas / Refrigeration

Heavy Industrial

Power / Co-Generation Plants

Steel and Iron Works

Commercial

Pulp and Paper Mills

Oil Refineries and Oil Field

Ship Building

Hydrocarbon Processing

Gas Piping

Local Area Energy Supply

Industrial



Shandong Shengfei Machinery Co., Ltd.

Tel: +86 150 6628 6136 Fax: +86 (0) 532-84688513

Website: www.shengfeimachinery.com

Email: sales@shengfeimachinery.com

STANDARD	PRODUCTION RANGE		
	ANSI Class 150	ANSI Class 300	ANSI Class 600
RATING -PSI	285	740	1440
RATING -BAR	20	50	100
SIZE -INCH	2-60	2-48	2-24
SIZE-MM	50-1500	50-1200	50-600
TESTING	API 598, EN-12266-1		
FACT TO FACE SPECIFICATIONS	ANSIB16.10 / API609 / MSS-SP-68 / ISO 5752 / BS5155 / EN 558		
END FLANGE SPECIFICATIONS	ASME B16.5: Class 150, 300, 600, 900 JIS B2210: 10K, 16K, 20K DIN ISO PN10, PN16, PN25, PN40, PN64, PN100, PN150		
CONNECTION	Wafer, Lugged, Semi-lugged, Double Flanged		
OPERATOR - MANUAL	Bare Stem, Lever Handle, Worm Gear Operator		
OPERATOR -AUTOMATIC	Electric Motor, Pneumatic Double Acting, Pneumatic Spring Return		
MAIN MATERIALS			
BODY	Carbon Steel (A216-WCB) 316 SS(A351-CF8M)		
DISC	316SS(A351-CF8M)		
STEM	17/4PH(A564-630)		
SEAT	PTFE, RTFE, 316 SS, Inconel, PTFE+316 SS, RTFE+316SS		
SHAFT BEARING	316 SS+DuPont PTFE		
PACKING SEAL	PTFE, Graphite		
SEAT MATERIALS and RATING			
PTFE	Class VI, Bubble Tight		
RTFE	Class VI, Bubble Tight		
316 SS	Class VI Bubble Tight (small size), Class V (large size)		
INCONEL	Class VI Bubble Tight (small size), Class V (large size)		
PTFE+316 SS	Class VI Bubble Tight, Class V w/Preferred Flow After Fire		
RTFE+316 SS	Class VI Bubble Tight, Class V w/Preferred Flow After Fire		



DOUBLE OFFSET/ECCENTRIC DESIGN

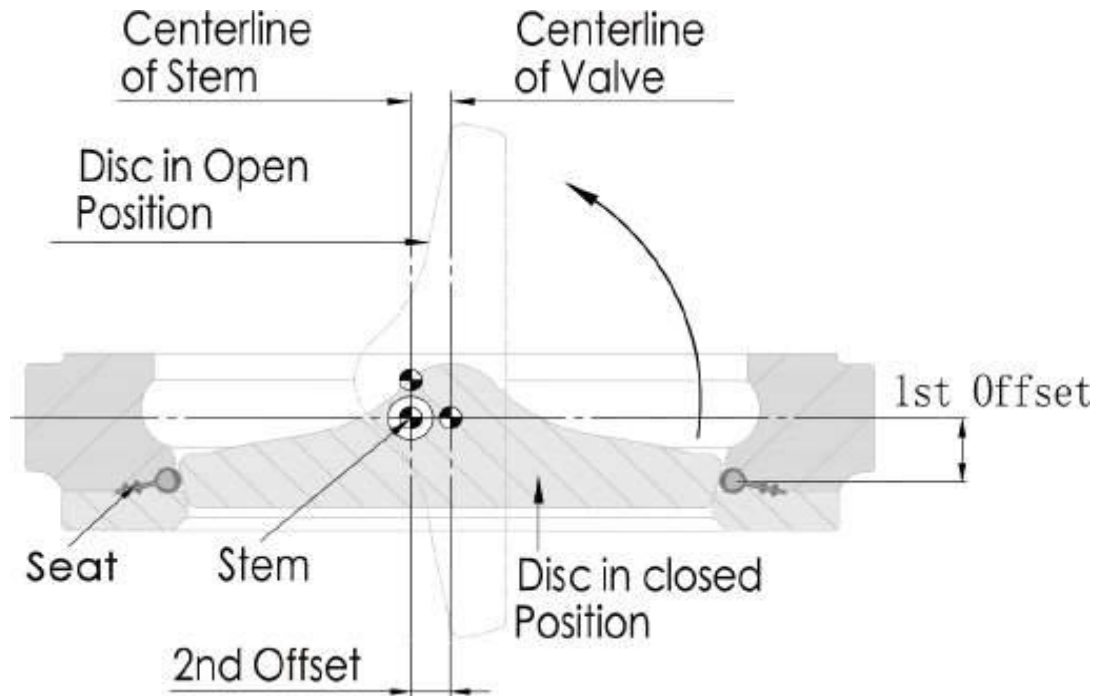

The double offset design of the SHENGFEI High Performance Butterfly Valves assures reduced seat wear and bidirectional, zero leakage shut off throughout the full pressure range. At the initial point of disc opening, the offset disc produces a cam-like action, pulling the disc from the seat. This cam-like action reduces seat wear and eliminates seat deformation when the disc is in the open position. When open, the disc does not contact the seat, therefore seat service life is extended and operating torques are reduced. As the valve closes, the cam-like action converts the rotary motion of the disc to a linear type motion to effectively push the disc onto the seat. The wiping action of the disc against the seat prevents undesirable material build-up from slurry or suspended solids.



UNIQUE VALVE SEAT DESIGN - METAL SEAT

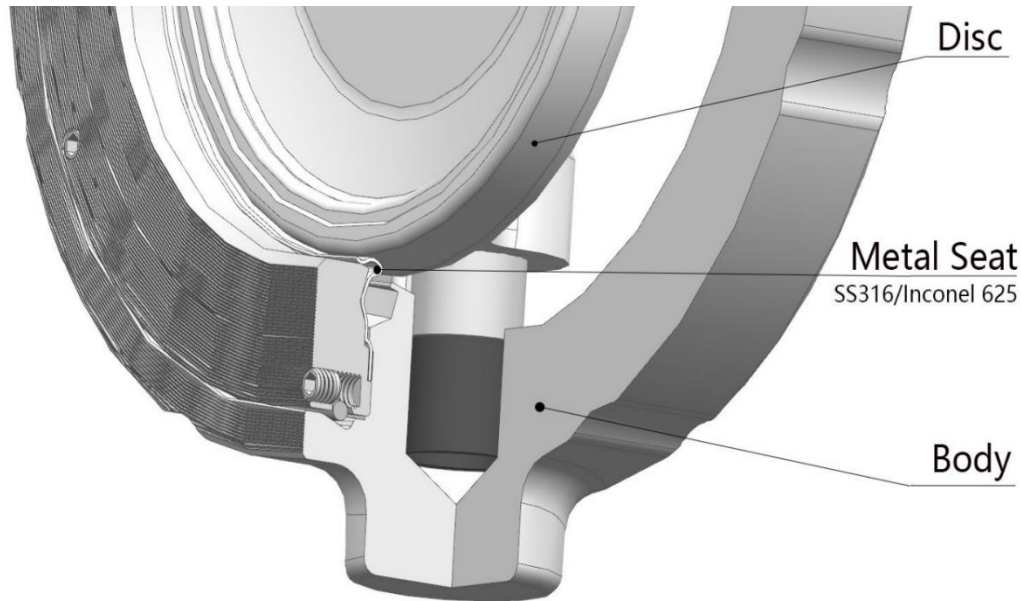

The SHENGFEI metal-to-metal seat high performance butterfly valve are with metal seat for higher tensile strength and the disc is case hardened by nitriding.

The Metal seat, by its dynamic and flexible design, applies enough force per linear inch against the disc edge (Rock-well Hardness of C66 to C70) to obtain an optimum sealing characteristic while controlling the loads between the metal surfaces.

The SHENGFEI metal-to-metal seat valve is utilized for temperatures up to 900°F, (482°C) in compliance with ASME B16.34 pressure/temperature specifications. Leakage is rated at Class V per ASME FCI 70-2.



PRINCIPLE OF SEAT SEALING - METAL SEAT

Figure 1 PRINCIPLE OF METAL SEATING

Metal-to-metal sealing is accomplished by the “line contact” between a spherical surface and conical surface. Figure 1 illustrates a typical globe control valve seat and plug. The plug seating surface is the segment of a sphere; when engaged against the seat ring, a line contact seal is achieved.

In a metal seat design, it is necessary to apply enough force per linear inch to maintain a tight metal-to-metal contact between the sealing members; however, high linear thrust can cause a collapse of the seating members (“bearing failure”)

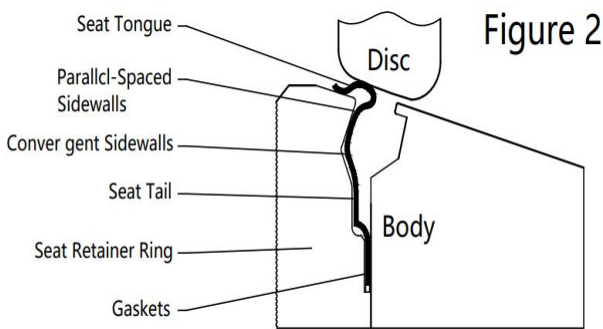
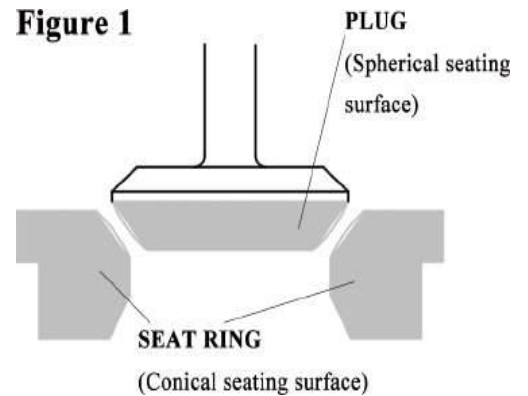

Figure 2 DISC CLOSED, Self-Energized Seal

In Figure 2, the disc and seat are engaged, and the process fluid is under low pressure. The spherical edge of the disc, with a larger diameter than the conical seat tongue, imparts a thrust of approximately 600 pounds per linear inch against the seat. The mechanical properties and shape of the metal seat allow it to both flex and maintain a constant thrust against the disc.

This controlled loading prevents the occurrence of bearing failure and reduces the leakage and wear between the components.

Figure 3 DISC CLOSED, Pressure-Energized Seal (Seat Upstream)

As line pressure increases, the process fluid enters the sidewall area and applies a load against the parallel-spaced sidewall and convergent sidewall of the metal seat. The seat moves towards the downstream sidewall, as shown in Figure 3. The cavity shape confines the seat movement and directs the movement radially inward towards the disc; the higher the line pressure, the tighter the line contact between the disc and seat. The metal seat, shaped by a special hydro forming process, is able to flex under these loads and return to its original shape after removal of the loads.

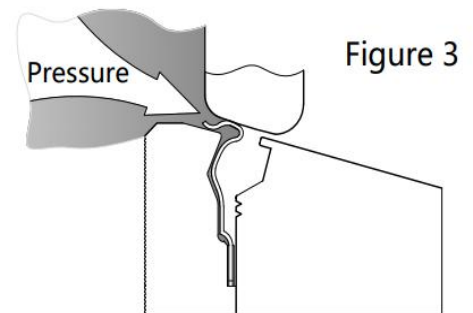

Figure 4

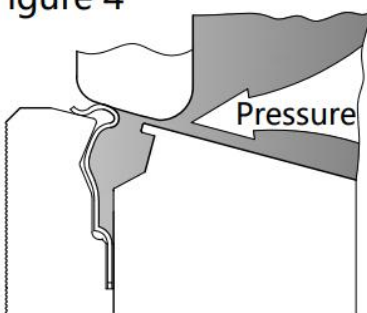
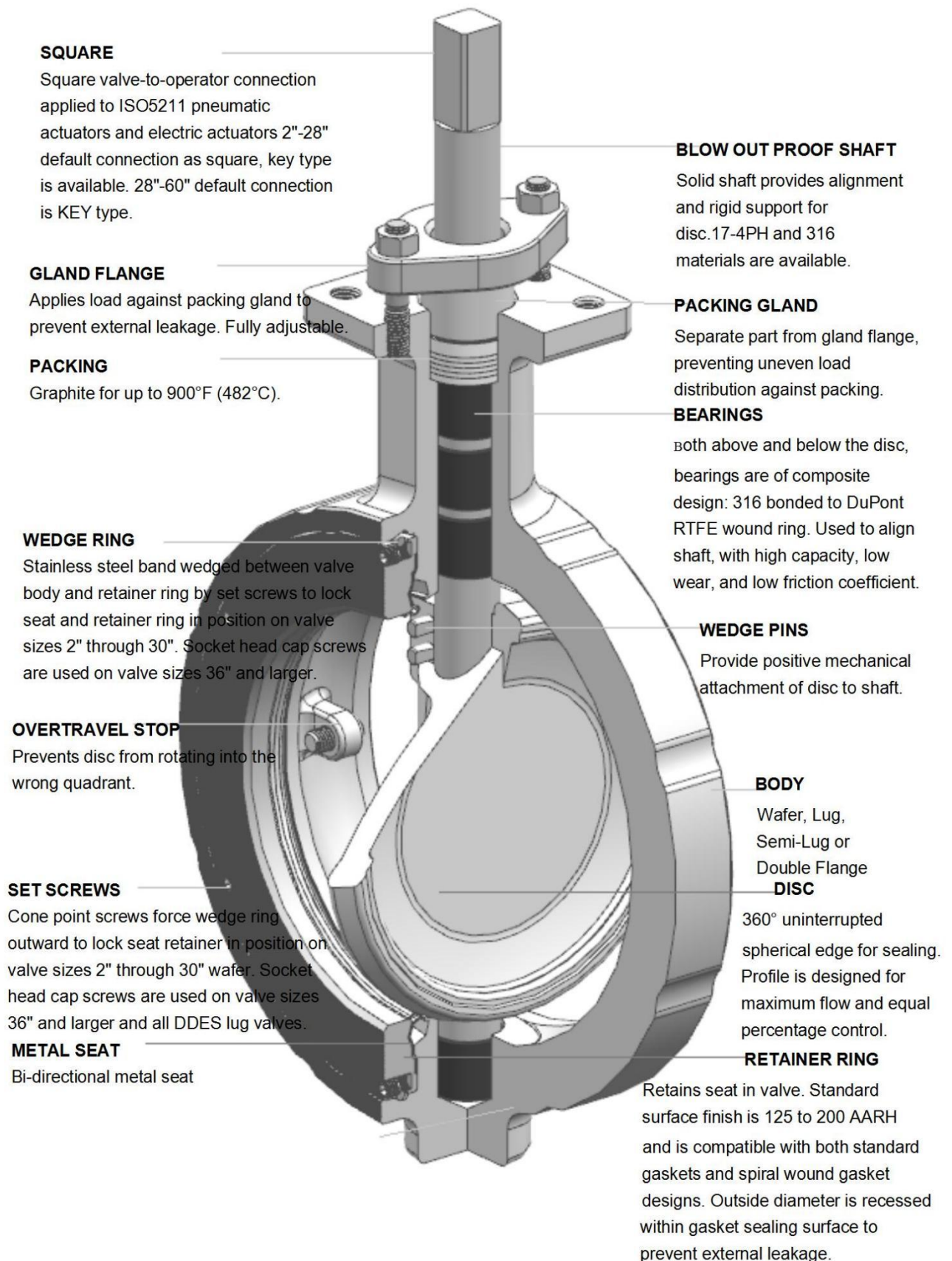

Figure 4 DISC CLOSED, Pressure-Energized Seal (Downstream)

The SHENGFEI valve is bi-directional. The cavity and seat sidewalls are symmetrically designed to permit, confine and direct movement of the seat to the disc to dynamically seal with line pressure in the seat downstream direction, as in Figure 4. Recommended installation direction is “SUS” (seat upstream), as in Figure 3.



VALVE COMPONENTS - METAL SEAT





HIGH PERFORMANCE BUTTERFLY VALVE DIMENSIONS PN16/PN25

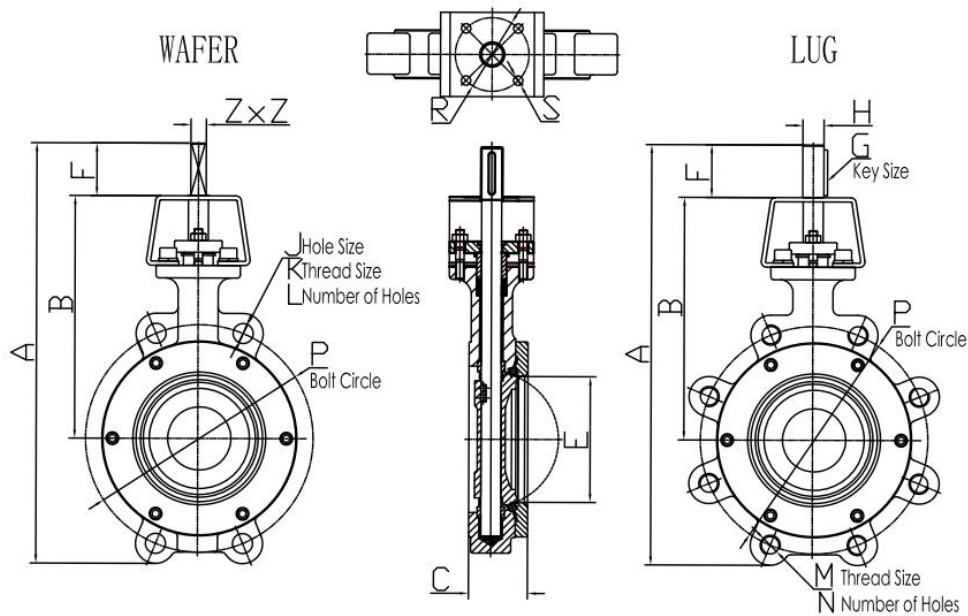

PN 1.6 MPa / PN 2.5 MPa

VALVE SIZE		WAFER	LUG	B	C	E	F	ZxZ		J	K	L	M x N		P	R	S	WEIGHT (Kg)	
DN	ins	A	A					G	H				PN1.6 PN2.5	PN1.6 PN2.5	mm	mm		WAFER	LUG
50	2"	257	258	193	43	60.12	27	11*11					M16X4 M16X4	125	φ70	4Xφ9		4.4	4.8
65	2½"	260	260	193	46	69.5	27	11*11					M16X4 M16X8	145	φ70	4Xφ9		4.9	5.3
80	3"	294	289	218	49	82.44	27	11*11					M16X8 M16X8	160	φ70	4Xφ9		5.6	6.5
100	4"	335	338	239	52	105.7	27	14*14					M16X8 M20X8	180 190	φ70	4Xφ9		8	11.5
125	5"	373	375	263	56	128.06	30	17*17					M16X8 M24X8	210 220	φ70	4Xφ9		10.5	13.5
150	6"	402	408	277	61	151.8	32	17*17					M20X8 M24X8	240 250	φ70	4Xφ9		13.5	16.5
200	8"	466	471	317	63.5	195.3	45	17*17					M20X12 M27X12	295 310	φ70	4Xφ9		20.6	24.5
250	10"	535	544	348	71	244.7	50	22*22		oval		2	M24X12 M21X12	355 370	φ102	4Xφ11		39	45.5
300	12"	625	630	400	82	291.9	60	27*27		oval		2	M24X12 M27X16	410 430	φ140	4Xφ18		55	67.5
350	14"	712	701	417	92	339.2	60	27*27		oval		4	M24X16 M30X16	470 490	φ140	4Xφ18		68	115
400	16"	792	792	476	101.8	387.4	70	27*27		oval		4	M27X16 M33X16	525 550	φ165	4Xφ21		116	132
500	20"	965	965	598	127	489.8	90	36*36			M30 M33	4	M30X20 M33X20	650 660	φ165	4Xφ21		185	220
600	24"	1097	1097	672	153.5	585.4	110	46*46			M33 M36	4	M33X20 M36X20	770 770	φ165	4Xφ21		290	310
700	28"	1232	1232	738	165	689.9	148.7	46*46			M33 M39	4	M33X24 M39X24	840 875	φ165	4Xφ21		495	579
800	32"	1357	1357	796	191	767.1	148.7	22	80		M36 M45	4	M36X24 M45X24	950 990	φ165	4Xφ21		736	922
900	36"	1502	1502	925	210	864.0	158.2	22	80		M36 M45	4	M36X28 M45X28	1050 1090	φ254	8Xφ17		871	1160
1000	40"	1634	1634	953	241	940.0	158.2	25	105		M39 M52	4	M39X28 M52X28	1170 1210	φ254	8Xφ17		1728	1779
1200	48"	1897	1897	1102	254	1171.0	178.2	32	115		M45 M52	4	M45X32 M52X32	1390 1420	φ298	8Xφ22		2074	2548
1350	54"	2090	2090	1209	273	1332.0	178.2	36	140		M45 M56	4	M45X36 M56X36	1590 1640	φ298	8Xφ22		3175	3210



HIGH PERFORMANCE BUTTERFLY VALVE DIMENSIONS PN40

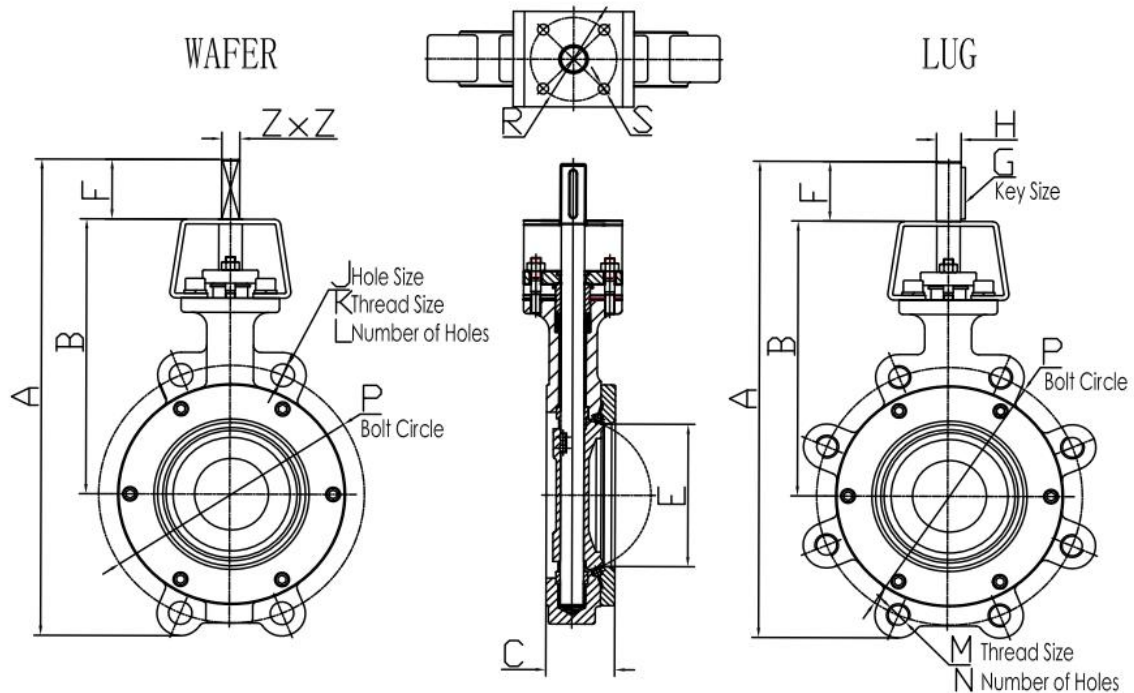

PN 4 . 0 M P a

VALVE SIZE		WAFER	LUG	B	C	E	F	Z x Z		J	K	L	M x N	P mm	R mm	S mm	WEIGHT (Kg)	
DN	ins	A	A					G	H								oval	oval
50	2"	257	266	190	43	60	27	11*11		oval		4	M16X4	125	φ70	4Xφ9	4.5	6.1
65	2½"	260	277	190	46	69	27	11*11					M16X8	145	φ70	4Xφ9	5	7
80	3"	294	311	216	49	82	27	11*11					M16X8	160	φ70	4Xφ9	6.5	9
100	4"	335	349	235	52	106	27	14*14					M20X8	190	φ70	4Xφ9	8	14
125	5"	373	384	254	57	128	30	17*17					M24X8	220	φ70	4Xφ9	10.5	16.5
150	6"	403	428	278	61	152	32	17*17					M24X8	250	φ70	4Xφ9	16.5	22
200	8"	485	500	324	72	195	50	22*22					M27X12	320	φ102	4Xφ11	35	41
250	10"	549	574	356	83	247	60	27*27		oval		2	M30X12	385	φ102	4Xφ11	53	64
300	12"	668	668	427	92	294	70	27*27		oval		2	M30X16	450	φ140	4Xφ18	77	90
350	14"	773	773	467.1	118	342	80	36*36			M33	4	M33X16	510	φ165	4Xφ21	124	146
400	16"	902	902	586.5	136	387	80	36*36			M36	4	M36X16	585	φ165	4Xφ21	165	220
450	18"	970	970	626	152	440	90	36*36			M36	4	M36X20	610	φ165	4Xφ21	218	315
500	20"	1134	1134	674	161	492.1	100	45*45			M39	4	M39X20	670	φ165	4Xφ21	298	410
600	24"	1229	1229	780	182	587	120	22	80		M45	4	M45X20	795	φ254	8Xφ17	340	495
700	28"	1355	1355	840	225	667	130	25	105		M45	4	M45X24	900	φ254	8Xφ17	530	660
900	36"	1661	1661	1030	271	864	150	32	115		M52	4	M52X28	1140	φ298	8Xφ22	1230	1540
1000	40"	1710	1710	1055	292	910	160	36	140		M52	4	M52X28	1250	φ298	8Xφ22	1450	1980
1200	48"	1918	1918	1205	318	1180	180	40	160		M56	4	M56X32	1371.6	φ356	8Xφ32	2270	2890



Shandong Shengfei Machinery Co., Ltd.

Tel: +86 150 6628 6136 Fax: +86 (0) 532-84688513

Website: www.shengfeimachinery.com

Email: sales@shengfeimachinery.com

HIGH PERFORMANCE BUTTERFLY VALVE DIMENSIONS DOUBLE FLANGE

PN16/PN25

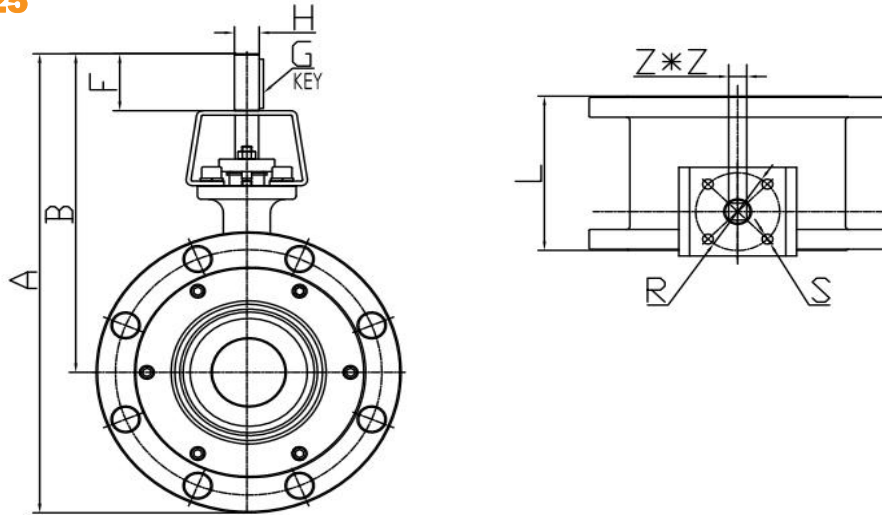

PN1. 6MP/PN2. 5MPa

VALVE SIZE		A	B	L		F	Z x Z		R mm	S mm	WEIGHT (Kg)	
DN	ins			Long	Short		H	G			Long	Short
80	3"	323	227	205	114	27	11*11		∅70	4X∅9	26	19
100	4"	373	259	229	127	27	14*14		∅70	4X∅9	34	25
125	5"	404	277	254	140	30	17*17		∅70	4X∅9	42	30
150	6"	431	291	267	140	32	17*17		∅70	4X∅9	49	34
200	8"	504	332	292	140	45	17*17		∅70	4X∅9	77	51
250	10"	551	348.2	300	165	50	22*22		∅102	4X∅11	102	78
300	12"	642	400	356	178	60	27*27		∅140	4X∅18	160	112
350	14"	738	462	381	191	60	27*27		∅140	4X∅18	198	141
400	16"	771	473	406	216	80	27*27		∅165	4X∅21	233	175
450	18"	906	589	432	223	90	36*36		∅165	4X∅21	272	213
500	20"	968	618	457	229	90	36*36		∅165	4X∅21	351	262
600	24"	1098	691	508	267	110	46*46		∅165	4X∅21	493	386
700	28"	1243	736		292	110	46*46		∅165	4X∅21		420
750	30"	1293	801	610	318	120	80	22	∅165	4X∅21	652	598
800	32"	1368	820		318	120	80	22	∅165	4X∅21		660
900	36"	1509	925	711	330	120	80	22	∅254	8X∅17	869	789



HIGH PERFORMANCE BUTTERFLY VALVE DIMENSIONS DOUBLE FLANGE

PN40

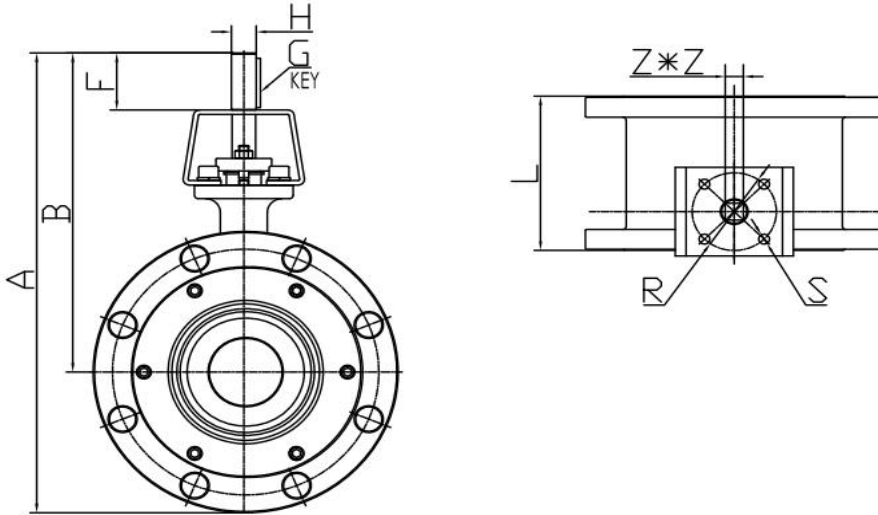

PN4. 0MPa

VALVE SIZE		A	B	L		F	Z x Z		R mm	S mm	WEIGHT (Kg)	
DN	ins			Long	Short		H	G			Long	Short
80	3"	332	228	202	114	27	11*11		φ70	4Xφ9	30	21
100	4"	385	258	305	127	27	14*14		φ70	4Xφ9	46	25
125	5"	418	277	381	140	30	17*17		φ70	4Xφ9	59	42
150	6"	453	295	403	140	32	17*17		φ70	4Xφ9	79	51
200	8"	520	330	419	152	50	22*22		φ102	4Xφ11	109	83
250	10"	583	361	475	165	60	27*27		φ102	4Xφ11	135	124
300	12"	694	433	502	178	70	27*27		φ140	4Xφ18	211	173
350	14"	759	467	762	191	80	36*36		φ165	4Xφ21	330	235
400	16"	910	586	838	216	80	36*36		φ165	4Xφ21	423	329
450	18"	981	625	914	225	90	36*36		φ165	4Xφ21	574	457
500	20"	1349	674	991	229	100	46*46		φ165	4Xφ21	660	522
600	24"	1238	780	1143	265	120	80	22	φ254	8Xφ17	862	808

NOTE:

Drawings are for reference only. Please contact factory for separate drawing for each size at sales@shengfeimachinery.com. SHENGFEI Machinery reserves the right to change product dimensions without notice.



INSTALLATION INSTRUCTIONS

PRE – INSTALLATION PROCEDURE

1. Remove the protective face covers from the valve.
2. Inspect the valve to be certain the waterway is free from dirt and foreign matter. Be certain the adjoining pipeline is free from any foreign material such as rust and pipe scale or welding slag that could damage the seat and disc sealing surfaces.
3. Actuators should be mounted on the valve prior to installation to facilitate proper alignment of the disc in the valve seat.
4. **The valve should be in the closed position.** Make sure the open and closed positions of the actuator correspond to the counter-clockwise to open direction of rotation of the valve.
5. Cycle the valve to the fully open position, then back to the fully closed position, checking the actuator travel stop settings for proper disc alignment.
6. Check the valve identification tag for valve class, materials, and operating pressure to be sure they are correct for the application.
WARNING: Injury or property damage may result if the valve is installed where service conditions could exceed the valve ratings.
7. Check the flange bolts or studs on both sides of the valve for proper size, threading, and length.

VALVE INSTALLATION PROCEDURE

The SHENGFEI High Performance Butterfly Valve can be installed in the pipeline with the shaft in the vertical, horizontal, or other intermediate position. Based on applications experience, however, in media with concentrations of solid or abrasive particles or media subject to solidification buildup, valve performance and service life will be enhanced by mounting the valve with the shaft in the horizontal position. All SHENGFEI valves are bi-directional and can be mounted in the pipeline in either flow direction; however, the preferred flow direction for all seat styles and materials is with the seat retainer ring located upstream (sus) to provide maximum seat protection.

1. For Wafer style (flangeless) valves:
 - a. Loosely install the lower flange bolts to form a cradle between the flanges. See Figure 1.
 - b. Note the flow direction arrow on the tag, place the valve and flange gaskets between the flanges, making sure the arrow on the tag points in the direction of the flow.
 - c. Install the remaining flange bolts, shifting the valve as necessary to permit the bolts to pass by or through the valve body.
 2. For Lug style (single flange) valves:
 - a. Note the flow direction arrow on the tag, place the valve between the flanges, making sure the arrow on the tag points in the direction of the flow.
 - b. Install the lower flange bolts loosely, leaving space for the flange gaskets.
 - c. After inserting the flange gaskets, install the remaining bolts.
 3. Using the sequence shown in Figure 2, tighten the flange bolts evenly to assure uniform gasket compression.
- Caution: The SHENGFEI valve should be centered between the flanges and gaskets to prevent damage to the disc edge and shaft as a result of the disc striking the flange, gasket, or pipe.
4. If an actuator is to be used, air hoses or electricity should be connected to the unit as specified by the actuator manufacturer.
 5. The valve is now ready for operation.

Remember: **Install the valve with the disc in the full closed position!** For more assistance, please feel free to contact SHENGFEI Machinery

